



DESCRIPTION

PT2253A is an electronic volume controller IC utilizing CMOS Technology specially designed for use on audio equipments. It has two (2) built-in channels making it ideally suitable for mono and stereo sound applications. PT2253A provides a wide frequency response range and a very low harmonic distortion to mention a few; thereby guaranteeing a highly effective and reliable performance.

FEATURES

- CMOS Technology
- Low Power Consumption
- Operating Voltage Range : $V_{cc} = 6 \sim 12 \text{ V}$
(Backup Voltage is up to 4 V)
- 0dB to -68dB attenuation controlled by 2dB/step
- 2 Channels in each chip
- Capable to control attenuation by a built-in oscillator and Up/Down Pin
- Single Power Supply or Dual Power Supplies of (+) and (-) can be used
- Wide Frequency Response Range
- Very Low Harmonic Distortion
- Available in 16 pin, DIP Package

APPLICATIONS

- Audio Equipment Volume Control
- Traditional VR Replacement



Electronic Volume Controller IC

PT2253A

BLOCK DIAGRAM

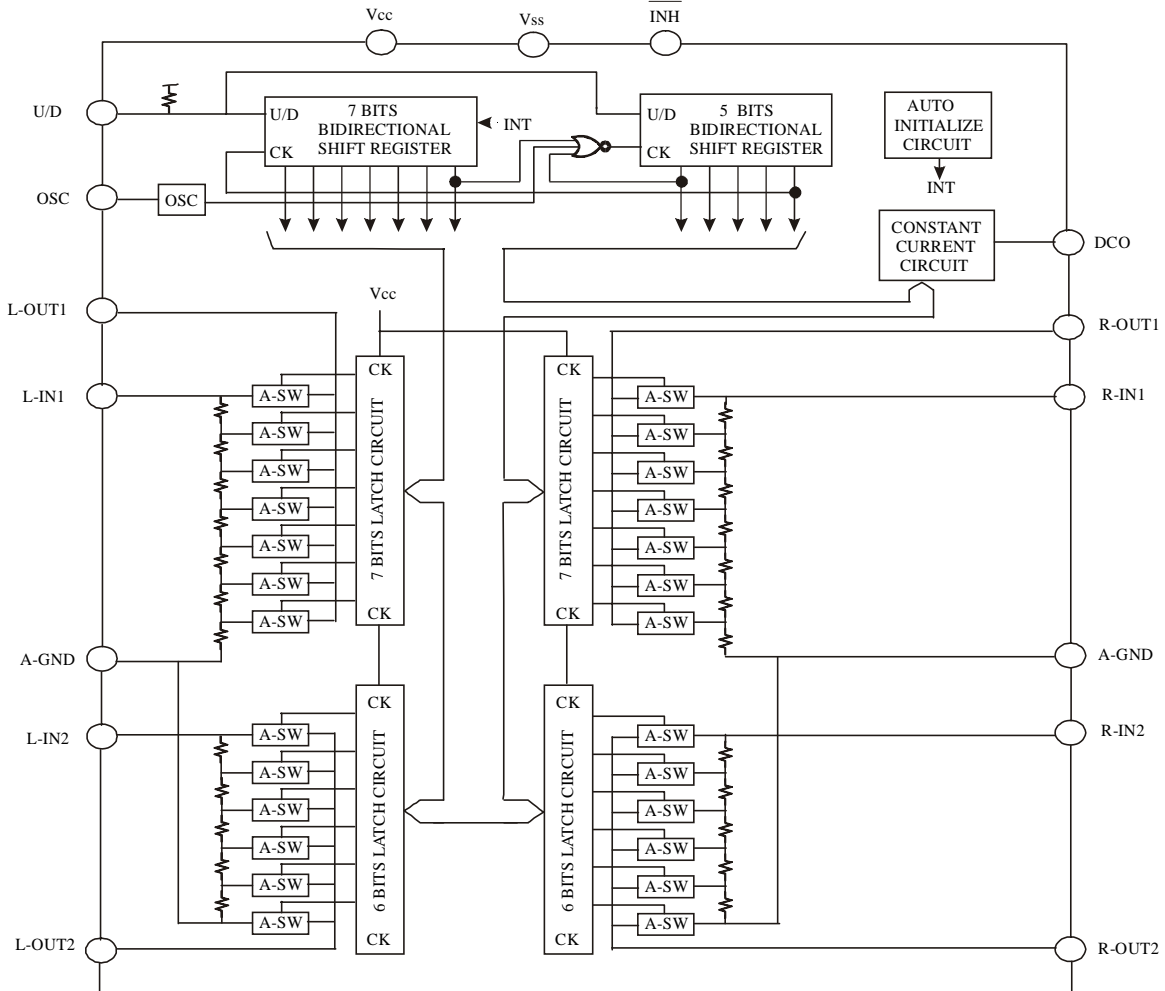

PIN CONFIGURATION

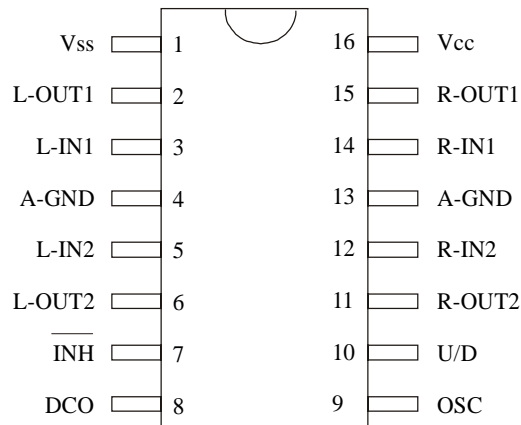

PT2253A



PIN DESCRIPTION

Pin Name	Pin No.	I/O	Description
Vss	1	Power	Negative Power Supply
L-OUT1	2	O	10dB/Step Attenuator Output A signal applied to 'IN' is attenuated into 7 steps from 0dB to -60dB.
L-IN1	3	I	10dB/Step Attenuator Input
A-GND	4	GND	Analog Ground Pin
L-IN2	5	I	2dB/Step Attenuator Input
L-OUT2	6	O	2dB/Step Attenuator Output A signal applied to 'IN' is attenuated into 5 steps from 0dB to -8dB.
$\overline{\text{INH}}$	7	I	Inhibit Terminal. At "L" level, all inputs and outputs are disabled. At "H" level, operation is normal.
DCO	8	O	DC Current Output Pin
OSC	9	I/O	RC Connecting Pin for the Oscillator
U/D	10	I	Attenuator Up/Down Control Pin
R-OUT2	11	O	2dB/Step Attenuator Output, same as L-OUT2.
R-IN2	12	I	2dB/Step Attenuator Input, same as L-IN2.
A-GND	13	GND	Analog Ground Pin
R-IN1	14	I	10dB/Step Attenuator Input, same as L-IN1.
R-OUT1	15	O	10dB/Step Attenuator Output, same as L-OUT1.
Vcc	16	Power	Positive Power Supply



FUNCTIONAL DESCRIPTION

Attenuation Setting

The Attenuation can be increased or decreased depending on the state of the U/D Pin (either “H” or “L” Level) by actuating the built-in oscillator. When power is applied, the attenuation is automatically set at -40dB.

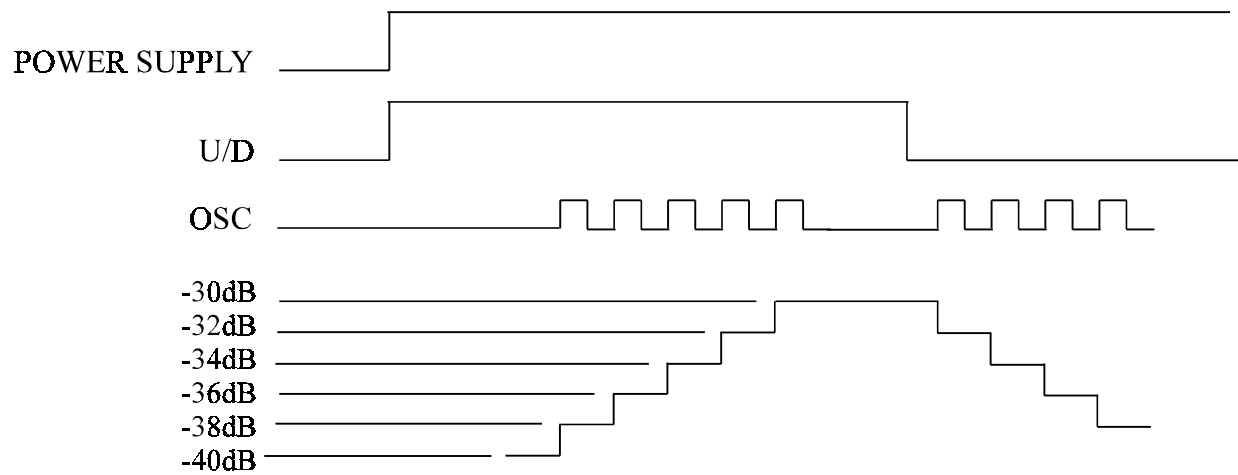

When the DOWN Key is pressed, the U/D Pin goes to the “L” Level and the oscillator is actuated in the down state. Thus, attenuation is increased.

Conversely, when the UP Key is pressed, the U/D Pin goes to the “H” Level and the oscillator is actuated in the up state. Thus, attenuation is decreased.

Oscillation frequency (f_{osc}) is dependent on the C_x and the R_x and is determined by the following equation:

$$f_{osc} = \frac{1}{0.7 (C_x) (R_x)} \text{ Hz}$$

where: $R_s \geq 3R_x$

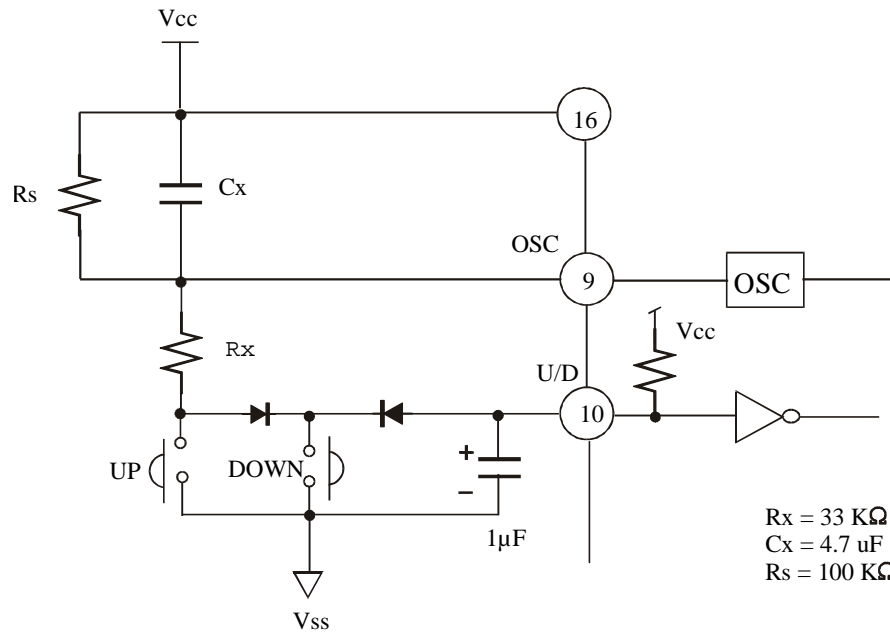

Attenuation Display Output

PT2253A has a DC Current Output Pin (DCO). The output level is divided into 13 steps. Please refer to the table below:

STEP	DCO	ATTENUATION
0	0	-64dB ~ ∞
1	1I	-60dB ~ -62dB
2	2I	-54dB ~ -58dB
3	3I	-50dB ~ -52dB
4	4I	-44dB ~ -48dB
5	5I	-40dB ~ -42dB
6	6I	-34dB ~ -38dB
7	7I	-30dB ~ -32dB
8	8I	-24dB ~ -28dB
9	9I	-20dB ~ -22dB
10	10I	-14dB ~ -18dB
11	11I	-10dB ~ -12dB
12	12I	-4dB ~ -8dB
13	13I	0dB ~ -2dB

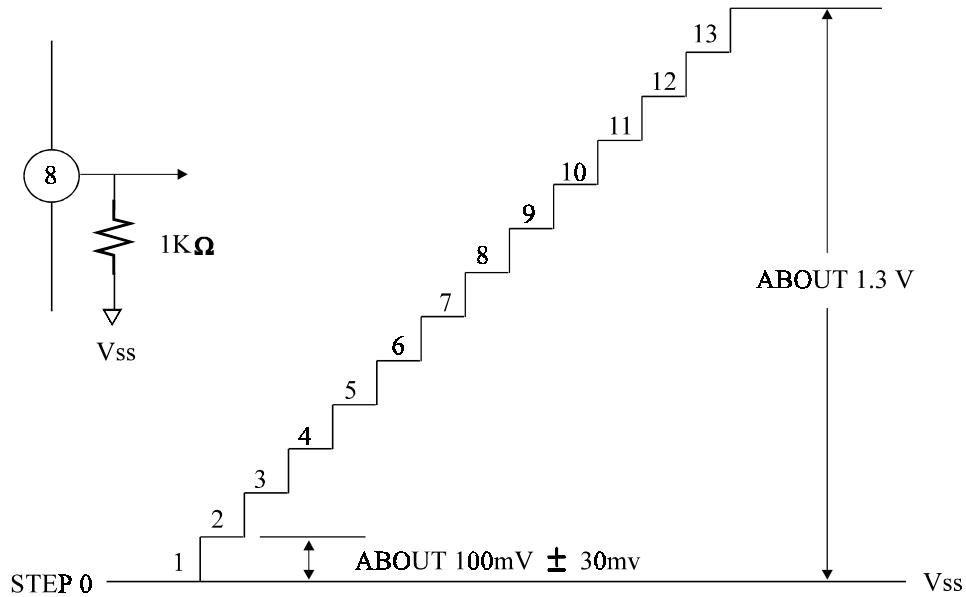

Current value may fluctuate depending on the IC. When high precision is required, use a variable resistor as a load resistor.

Attenuator

Attenuator 1 attenuates 0 ~ -60dB at 10dB/step.

Attenuator 2 attenuates 0 ~ -8dB at 2 dB/step.

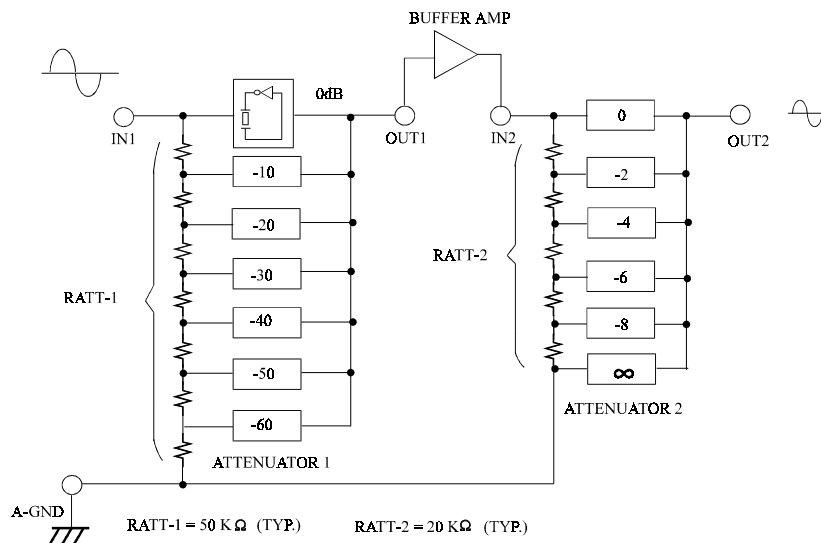



Electronic Volume Controller IC

PT2253A

If there is the possibility of excessive voltage in the attenuator, it is recommended that a protective diode be inserted. Please refer to the diagram below.

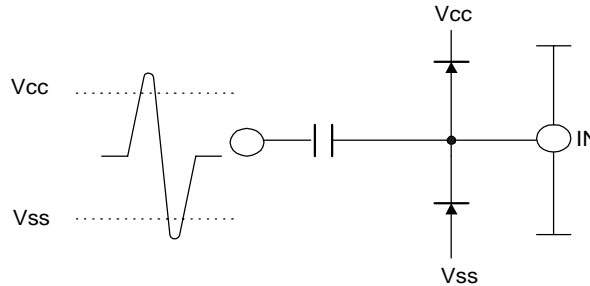

Power Supply

DUAL POWER SUPPLY

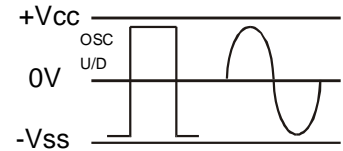
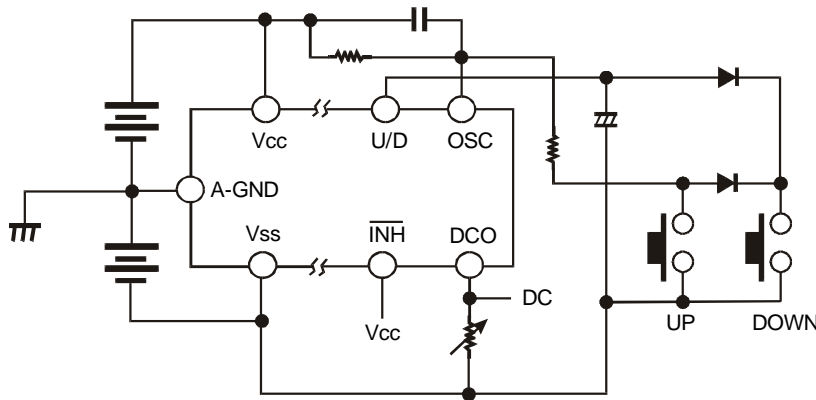

SINGLE POWER SUPPLY

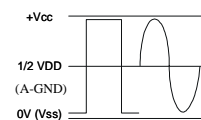
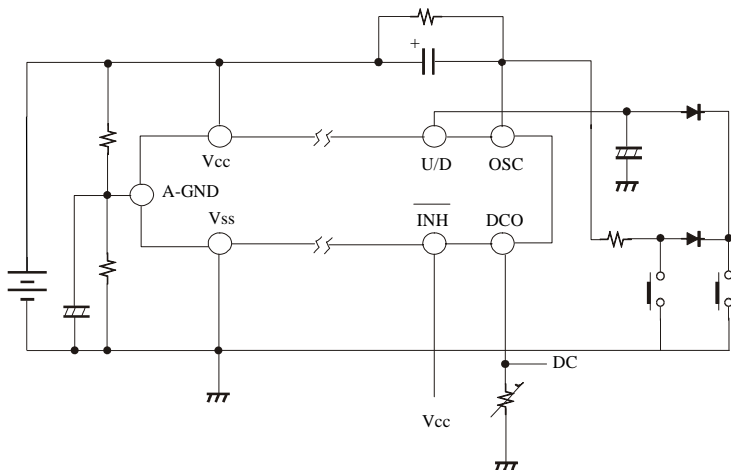



Initialization When Power ON

PT2253A has the built-in auto-initializing function for the during the Power ON period. It has the power supply on reset for the initialization of the chip. If the power supply rises too fast, the initialization may not be fully effected. For initialization to be fully effective, it is necessary to satisfy the following conditions:

1. The $\overline{\text{INH}}$ Terminal must be raised simultaneously with the Supply Voltage.
2. Initial attenuation level is -40dB

Please refer to the following diagram.

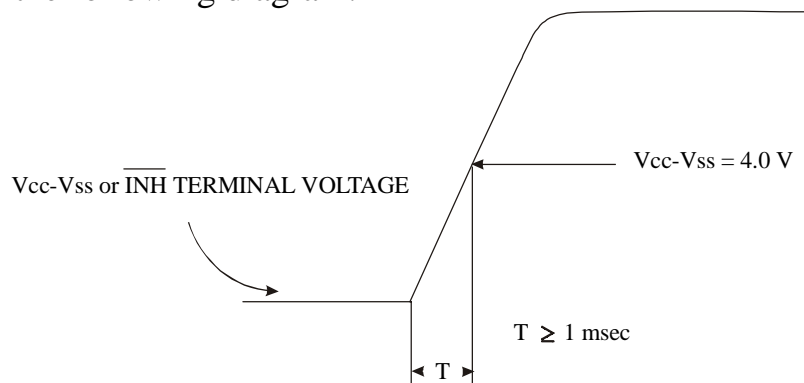

* If $V_{CC}-V_{SS}$ drops below 4.0 V, the auto-initializing function is actuated.

Back Up When Power OFF

When $\overline{\text{INH}}$ Pin is set at “L” Level, all input and output pins are disabled and the current consumption is reduced to the minimum. Under this conditions, the backup by means of a capacitor becomes possible. An example of this application when a backup capacitor is used is shown below.



Electronic Volume Controller IC

PT2253A

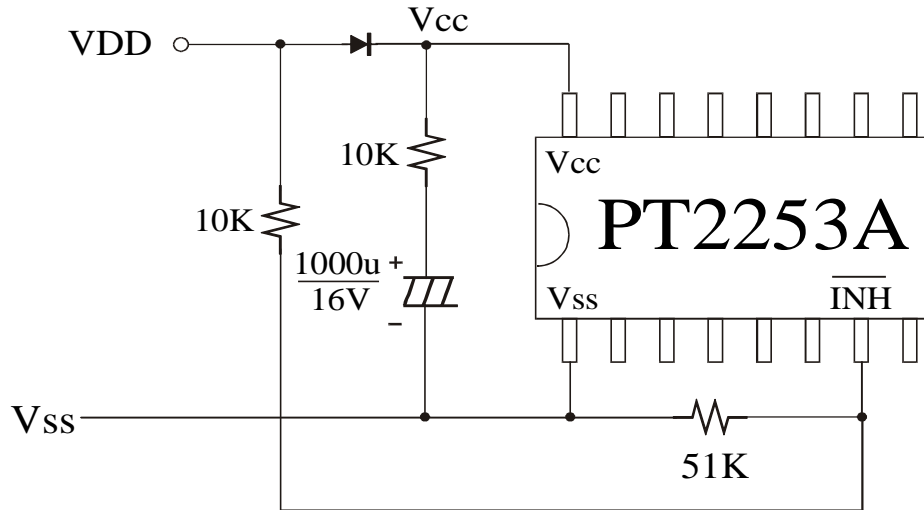

- If Vcc-Vss drops below 4.0 V, the backup becomes impossible.

DC ELECTRICAL CHARACTERISTICS

(Unless otherwise specified, Vcc = 12 V, Vss = 0 V and Ta = 25 °C)

PARAMETER	SYMBOL	CONDITION	MIN.	TYP.	MAX.	UNIT
Operating Supply Voltage	Vcc		6	-	12	V
Operating Supply Current	Icc		-	1	3	mA
Stand-by-Current	ISB	Vcc=12V INH=0V OSC=12V	-	-	10	uA
Input Voltage (INH,U/D)	“H” Level	V _{IH}	0.8 x Vcc	-	Vcc + 0.3	V
	“L” Level	V _{IL}	Vss - 0.3	-	0.2 x Vcc	
Attenuator 1 (10dB/step) Resistor	RATT-1	Attenuation Level is set to 0dB	25	50	70	kΩ
Attenuator 2 (2dB/step) Resistor	RATT-2	Attenuation Level is set to 0dB	10	20	28	kΩ
Max. Input Amplitude	Vin	Bias Vcc/2 = 6V Fin=1KHz ATT=0dB	-	-	4.0	Vrms
Operating Oscillation Frequency	fosc		5	-	10k	Hz
DCO Output Current	IDCO	1 Step	70	100	140	uA



ELECTRICAL CHARACTERISTICS

(Unless otherwise specified, Vcc = 6V, Vss = -6V, GND = 0V)

IN1 ~ OUT1

Characteristic	Symbol	Condition	Max.	Unit
Signal to Noise Ratio	S/N	ATT=0dB Fin=1KHz Vin=1.0Vrms	97	dB
Frequency Response	Fr	ATT=-10dB Fin=1KHz Vin=1.0Vp-p	657	KHz
Noise Floor	NF	Vin=0V, ATT=0dB	0.015	mv
Total Harmonic Distortion	THD	ATT=-10dB Fin=1KHz Vin=1.0Vrms	0.010	%

IN2 ~ OUT2

Characteristic	Symbol	Condition	Max.	Unit
Signal to Noise Ratio	S/N	ATT = 0dB Fin=1KHz Vin=1.0Vrms	95	dB
Frequency Response	Fr	ATT=-2dB Fin=1KHz Vin=1.0Vp-p	1820	KHz
Noise Floor	NF	Vin=0V ATT=0dB	0.022	mv
Total Harmonic Distortion	THD	ATT=-2dB Fin=1KHz Vin=1.0Vrms	0.009	%



APPLICATION CIRCUIT 1

Dual Power Supply (L-Channel Only)

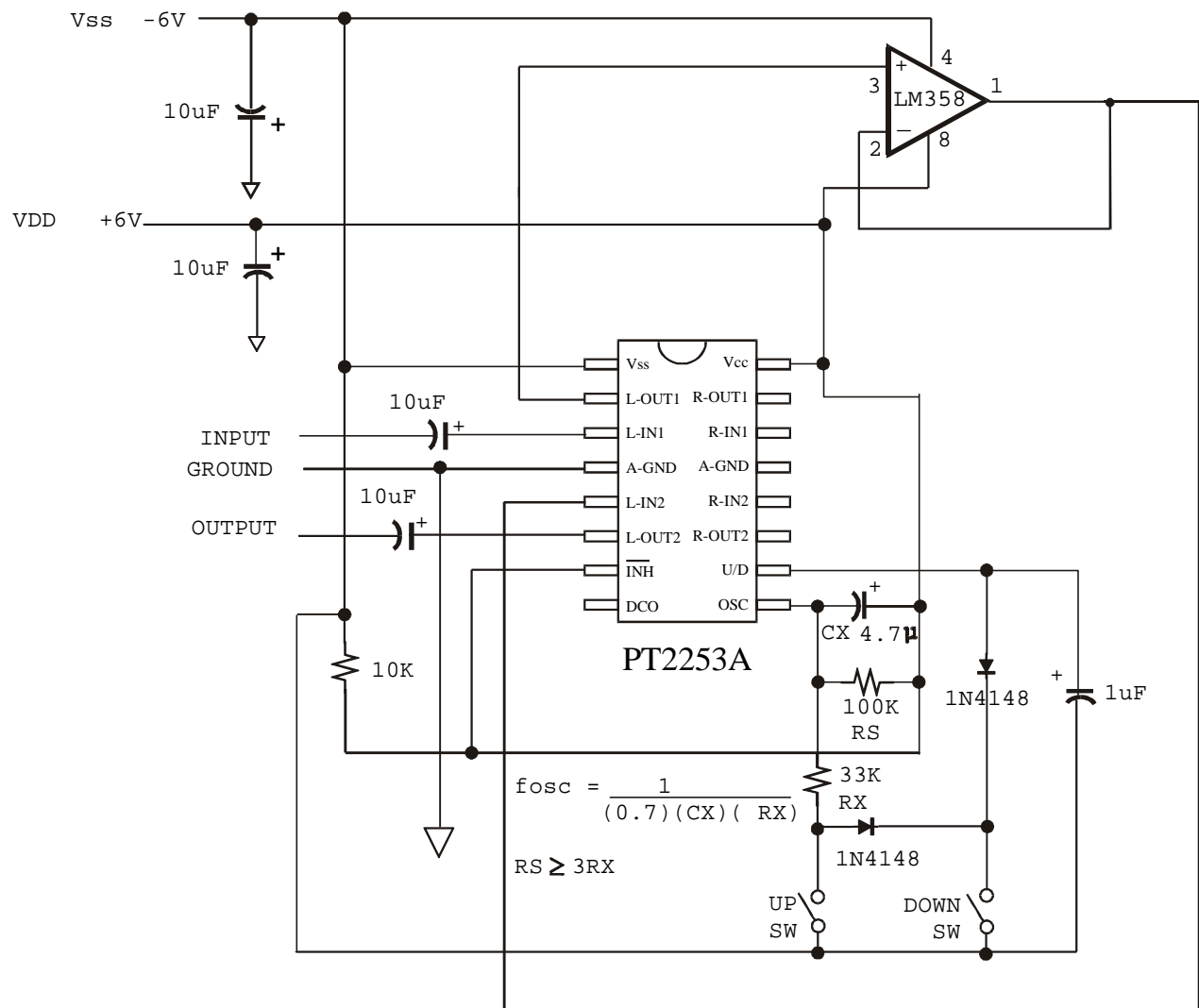



APPLICATION CIRCUIT 2

Dual Power Supply (L-Channel Only)

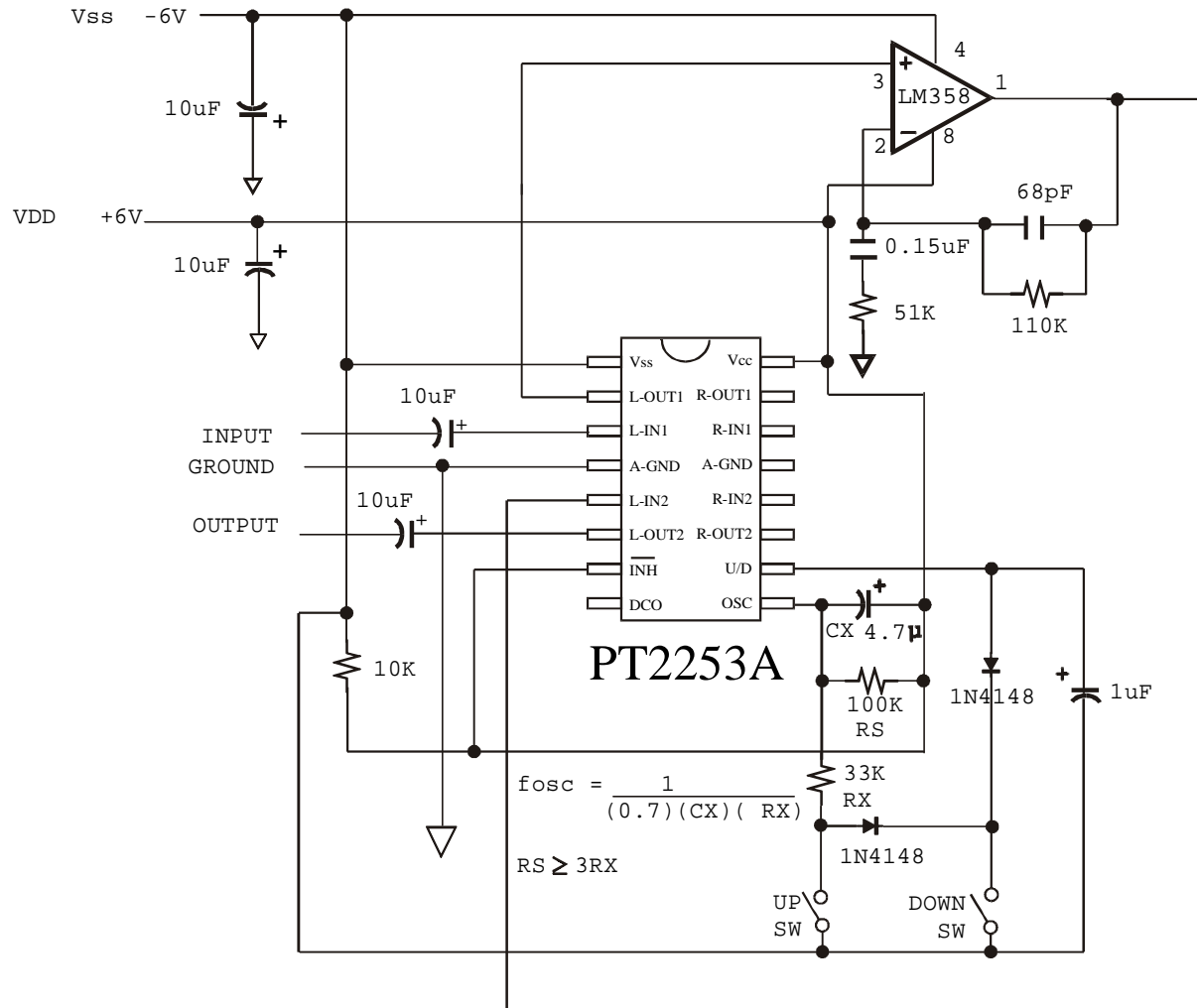

Note: Since the Buffer Amp between Att-1 and Att-2 is already 10dB Voltage Gain, higher input level may cause OP Amp's Output Clipping. To avoid unwanted distortion, the input signal level applied at IN-1 should not be over 1 Vrms.



APPLICATION CIRCUIT 3

Single Power Supply

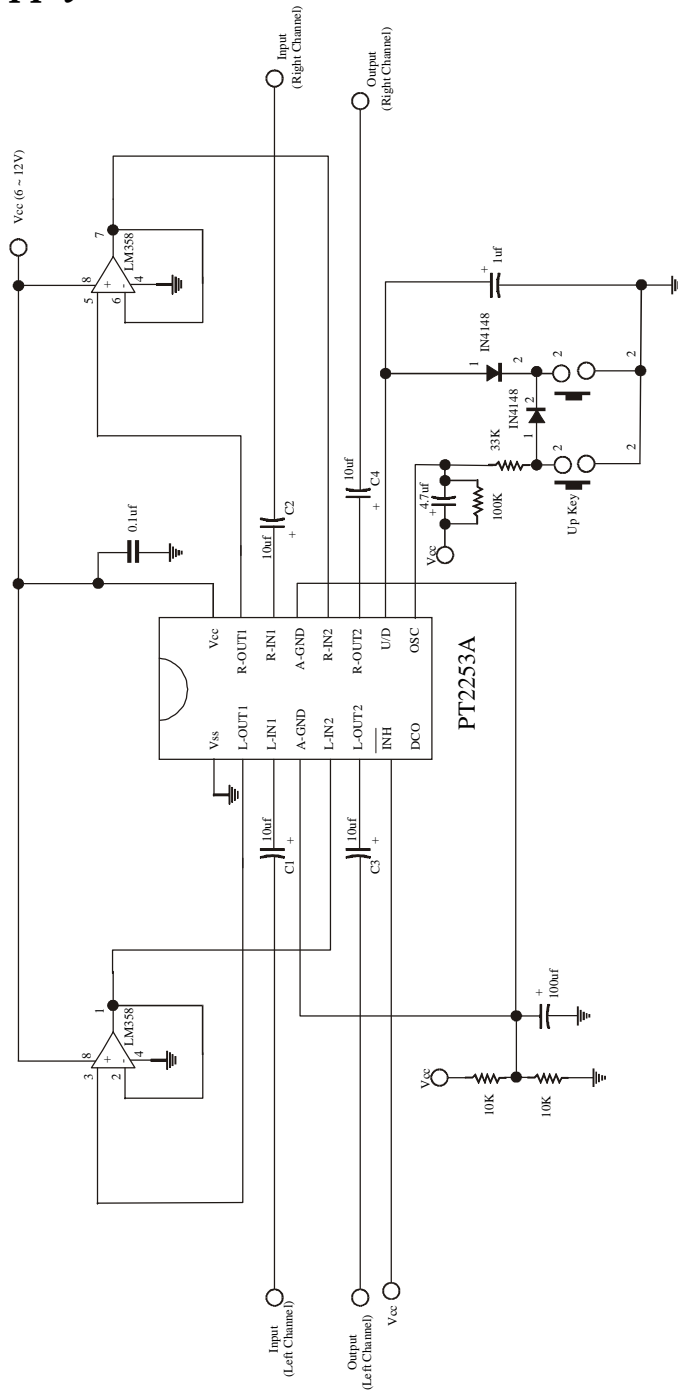



Electronic Volume Controller IC

PT2253A

APPLICATION CIRCUIT 4

Single Power Supply

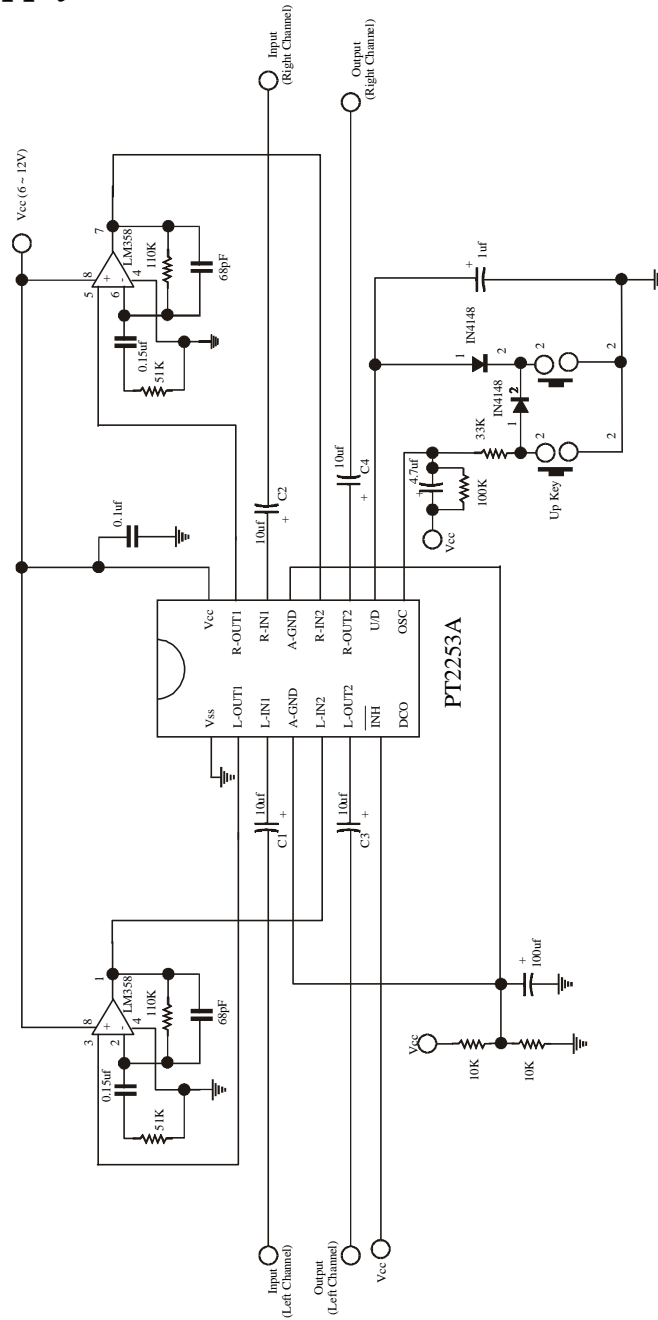

Note: Since the Buffer Amp between Att-1 and Att-2 is already 10dB Voltage Gain, higher input level may cause OP Amp's Output Clipping. To avoid unwanted distortion, the input signal level applied at IN-1 should not be over 1 Vrms.



ORDER INFORMATION

Valid Part Number	Package Type
PT2253A	16 Pins, DIP

PACKAGE INFORMATION

16 Pins, DIP Package

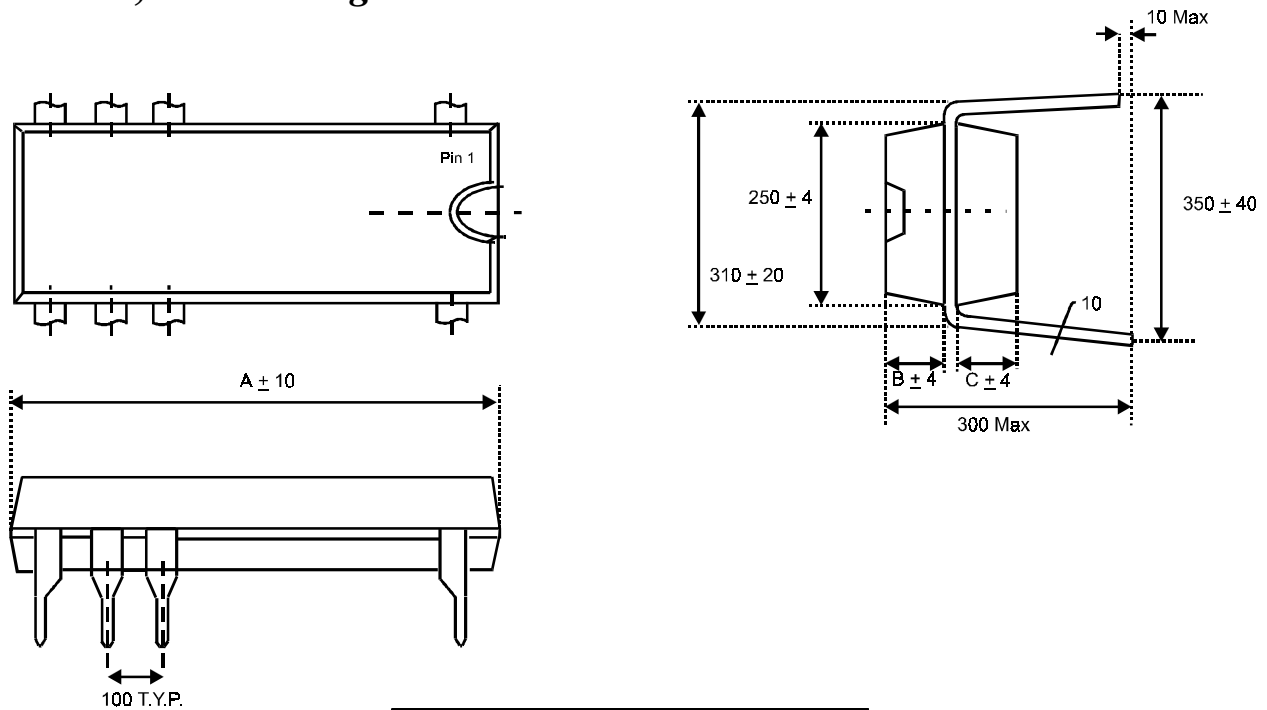

Symbol	Dimension in Mil
A	750
B	65
C	55